

60cc MINISWIFT "PROMOTIONAL" - TAG

		FEATURES - CARACTERISTIQUES	
		Cylinder Volume <i>Volume du cylindre</i>	59.00 cm ³
		Bore <i>Alésage</i>	41.80 mm
		Max. bore <i>Alésage max.</i>	42.10 mm
		Stroke <i>Course</i>	43 ±0.2 mm
		Cooling system <i>Système de refroidissement</i>	Air <i>Air</i>
		Inlet system <i>Système d'admission</i>	Piston valve <i>Jupe de piston</i>
		Number of carbs <i>Nombre de carburateurs</i>	1
Tillotson Carburettor <i>Carburateur Tillotson</i>	HW-31A (ØVenturi 17mm)	Cylinder / crankcase transfers n° <i>N° de canaux cylindre / carter</i>	2 / 2
Number of piston rings <i>Nombre de segments</i>	1	Inlet / exhaust ports number <i>N° lumières admiss / échapp.</i>	1 / 1
Big end conrod ball-bearing diam. <i>Diamètre palier tête de bielle</i>	18x24x15	Combustion chamber shape <i>Forme chambre de combustion</i>	Spherical <i>Sphérique</i>
Crankshaft ball-bearing diam. <i>Diamètre palier du vilebrequin</i>	20x47x14	Selettra ignition (adjustable) <i>Allumage Selettra (réglable)</i>	Analogue 2 Poles
Small end conrod ball-bearing diam. <i>Diamètre palier pied de bielle</i>	12x16x16	Distance between Conrod centers <i>Longueur (entre axe) de la bielle</i>	88 mm

DESCRIPTION OF THE MATERIAL DESCRIPTION DES MATERIAUX		PISTON
Conrod material <i>Matériel de la bielle</i>	Steel <i>Acier</i>	 <p>Min Weight (ring included) 60g Poids min. (avec segment) 60 g</p>
Crankshaft material <i>Matériel du vilebrequin</i>	Steel <i>Acier</i>	
Head Material <i>Matériel de la culasse</i>	Aluminium	
Cylinder Material <i>Matériel du cylindre</i>	Aluminium	
Liner material <i>Matériel de la chemise</i>	Iron <i>Fonte</i>	
Crankcase material <i>Matériel du carter</i>	Aluminium	 <p>Min Weight 80 g Poids min.</p>
Piston material <i>Matériel du piston</i>	Aluminium	
Piston rings material <i>Matériel des segments</i>	Iron <i>Fonte</i>	
Exhaust muffler material <i>Matériel du pot d'échappement</i>	Sheet-steel <i>Tôle acier</i>	
Ball-bearings <i>Roulements</i>	6204 type	

CRANKSHAFT - VILEBREQUIN

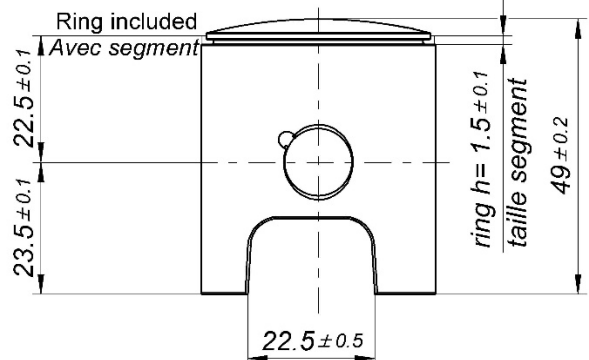
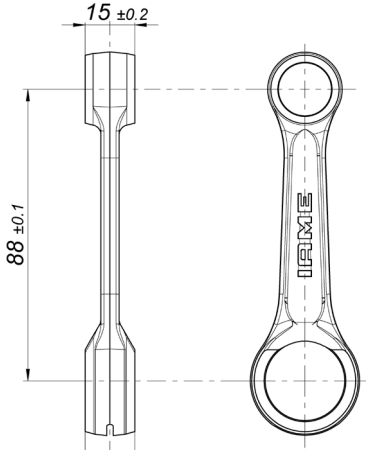
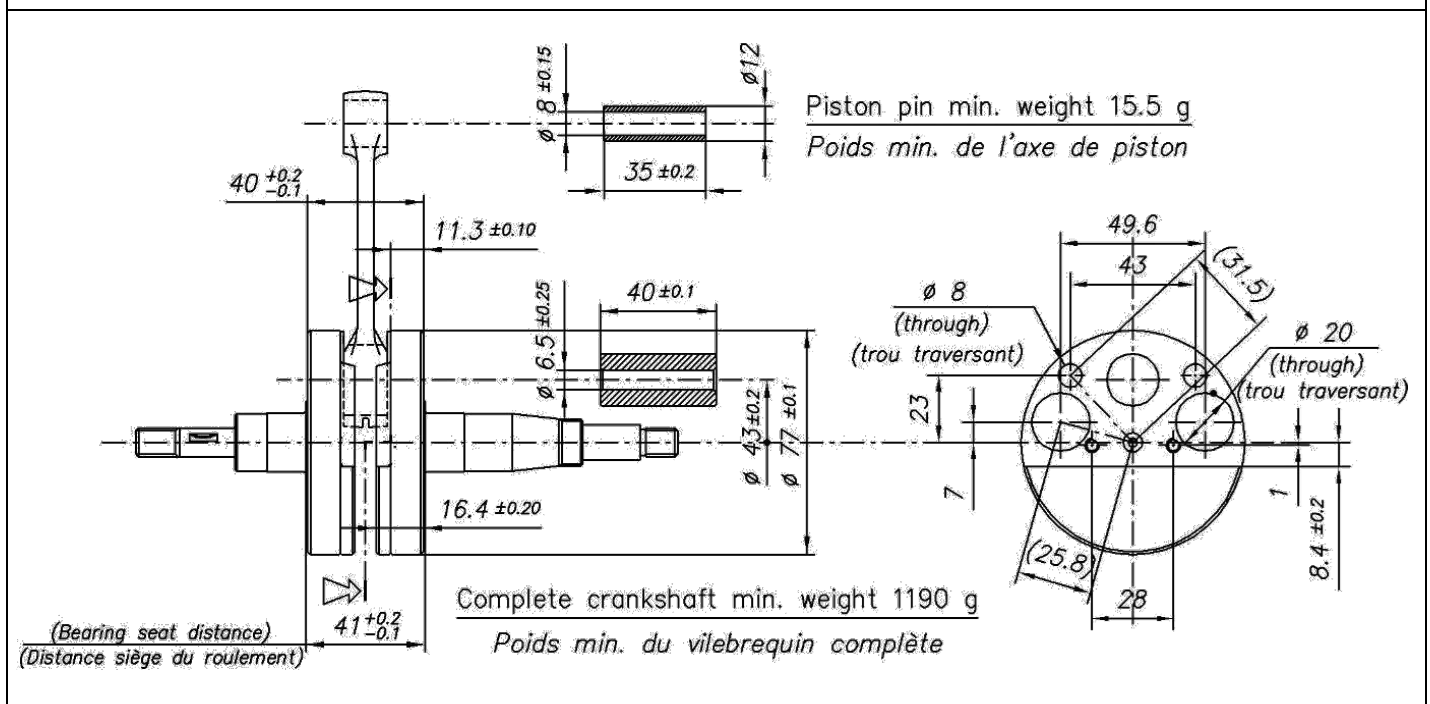

CYLINDER DEVELOPMENT – DEVELOPPEMENT DU CYLINDRE

TOOL IAME Cod. 10194

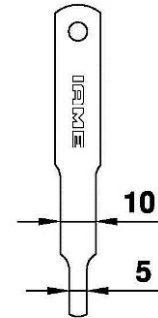
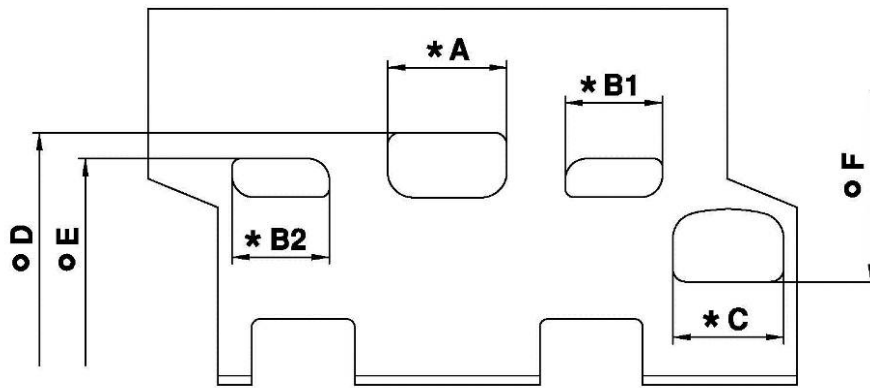

A	≤ 28.5 mm
B1 = B2	≤ 22.3 mm
C	≤ 26.5 mm
D	$155.5^\circ \pm 2^\circ$
E	$115.5^\circ \pm 2^\circ$
F	$143.0^\circ \pm 2^\circ$

* CHORDAL READING – LECTURE CORDALE

o ANGULAR READING BY INSERT A 0.2x5 mm GAUGE -
LECTURE ANGULAIRE PAR INSERTION D'UNE CALE DE 0.2x5 mm

USING IAME TOOL Cod. 10194 – UTILISER OUTIL

CYLINDER BASE VIEW VUE DE LA BASE DU CYLINDRE

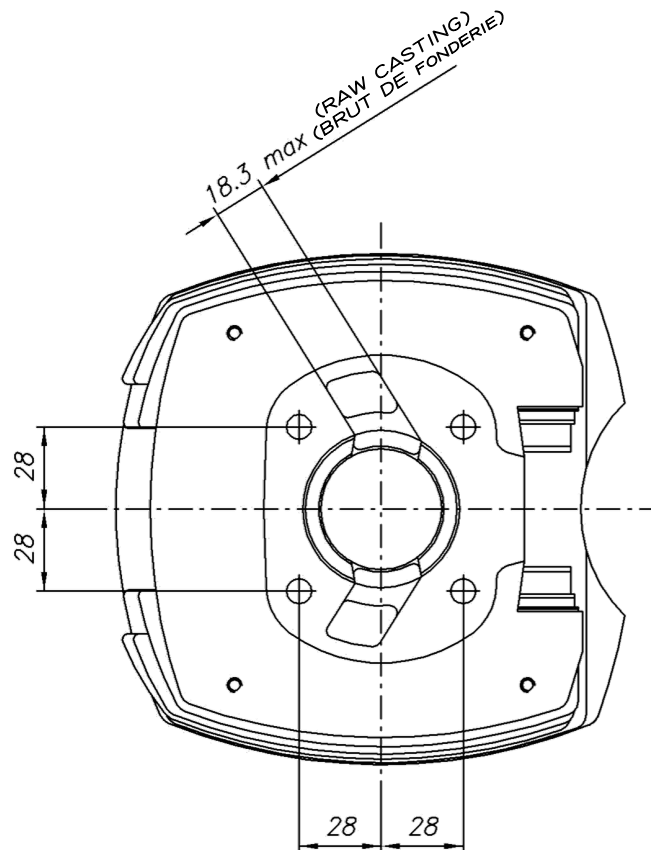

CYLINDER SECTION VIEW
 VUE EN SECTION DU CYLINDRE

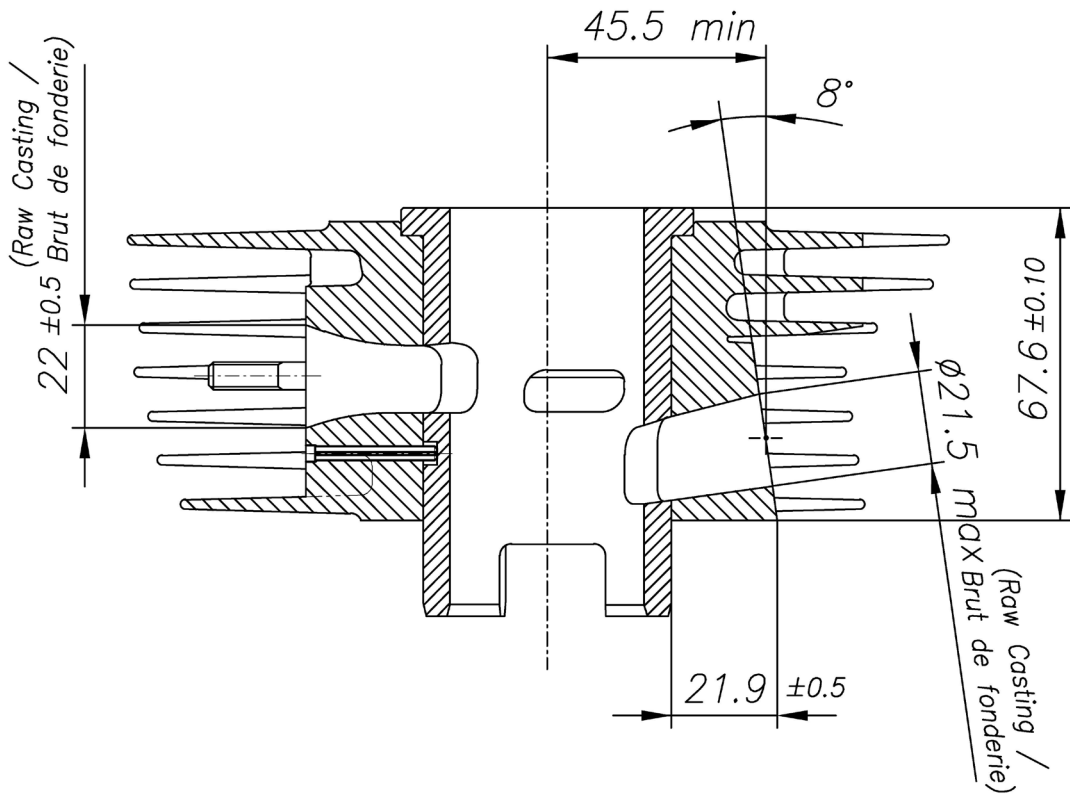
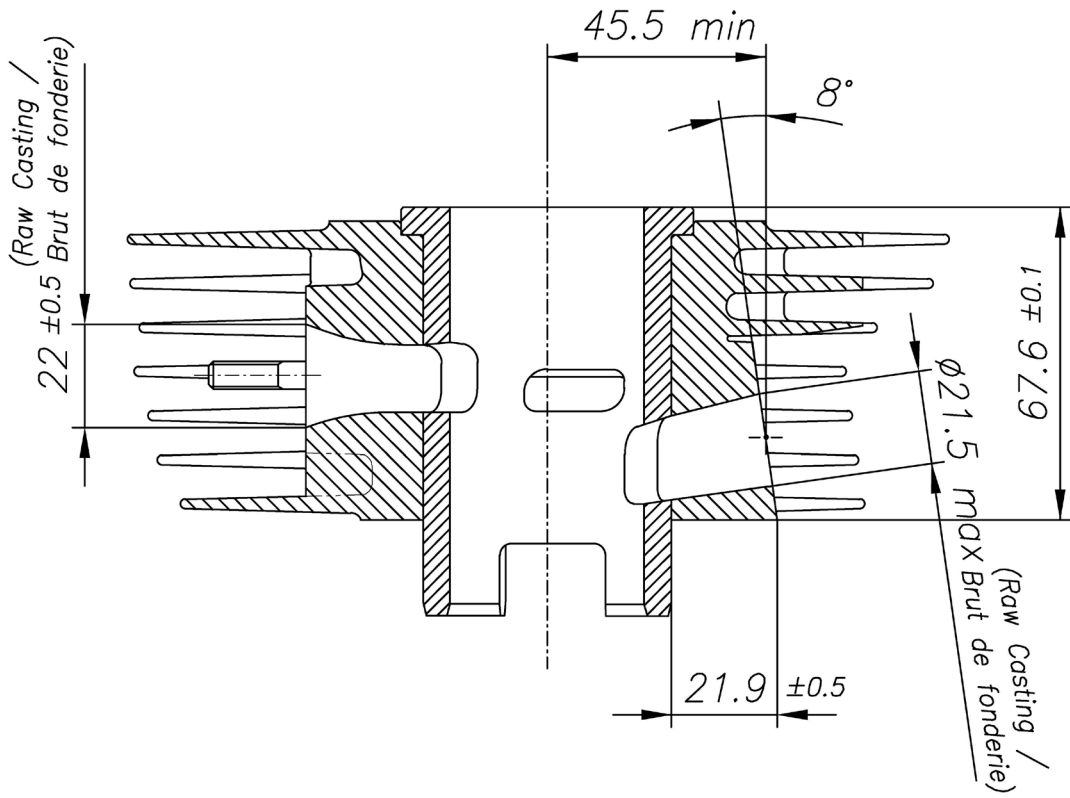

COMBUSTION CHAMBER VIEW
VUE DE LA CHAMBRE DE COMPRESSION

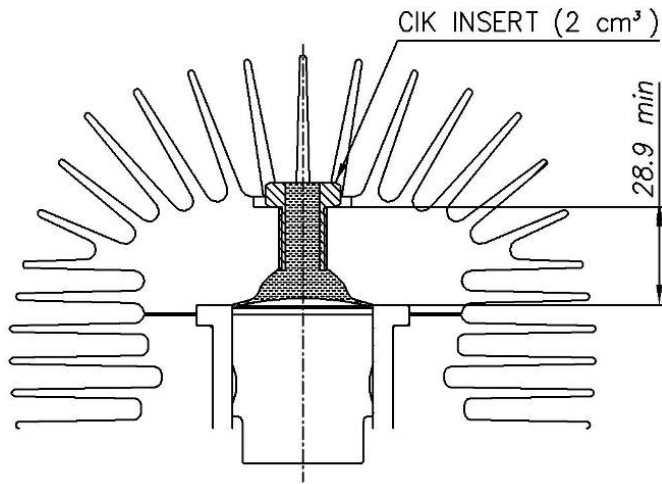

COMBUSTION CHAMBER VOLUME = 6.5 cm³ min.
VOLUME CHAMBRE COMBUSTION

CRANKCASE INSIDE VIEW
VUE A L'INTERIEUR DU CARTER

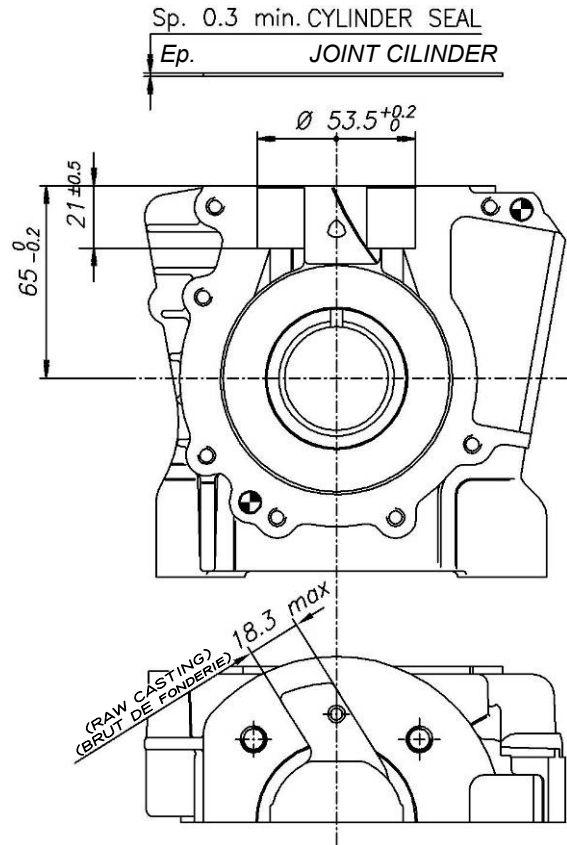

VENTURI CARB. DIMENSIONS AND THERMAL SPACERS
DIMENSIONS DU VENTURI DU CARBURATEUR ET ESPACEURS THERMIQUE

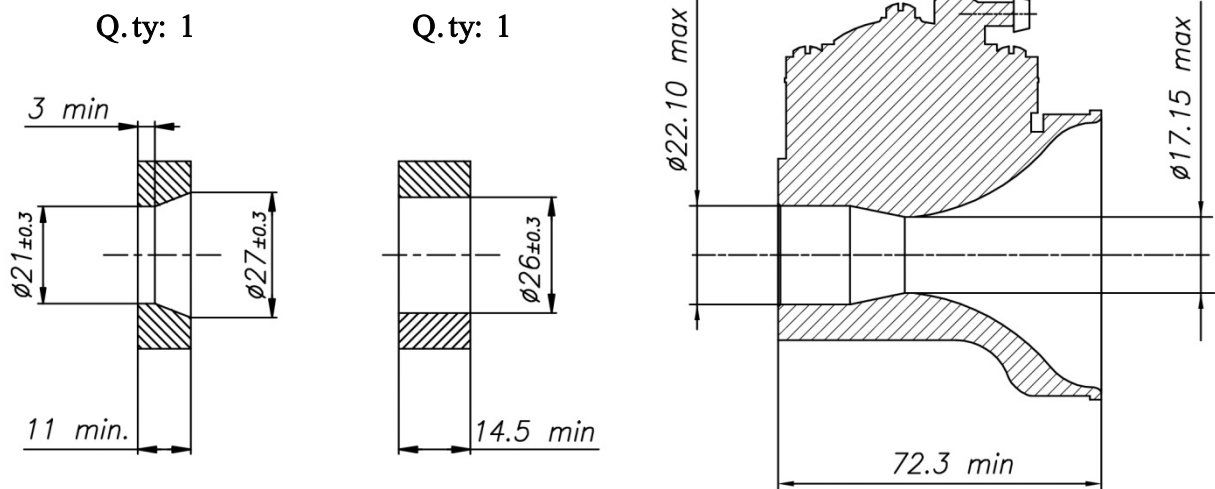

TILLOTSON MOD. HW-31A

INLET SILENCER
SILENCIEUX D'ASPIRATION

(CSAI OMOLOGATION N° 01/SA/14)

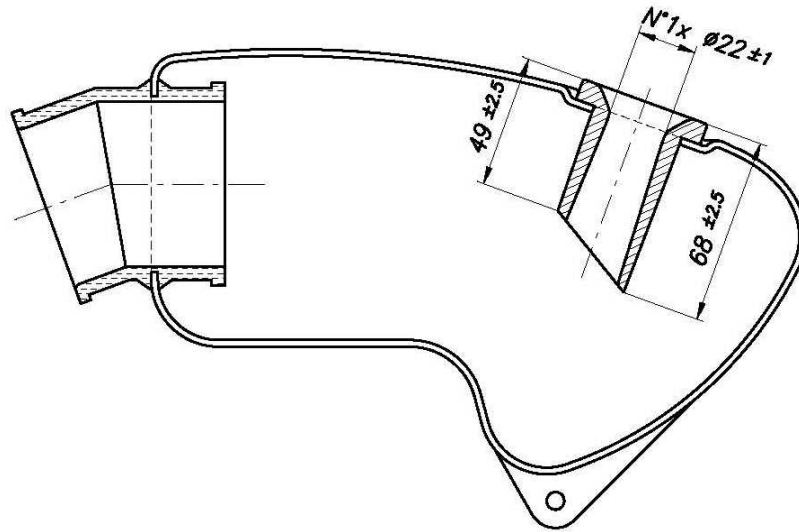

ALTERNATIVE INLET SILENCER
ALTERNATIVE SILENCIEUX D'ASPIRATION

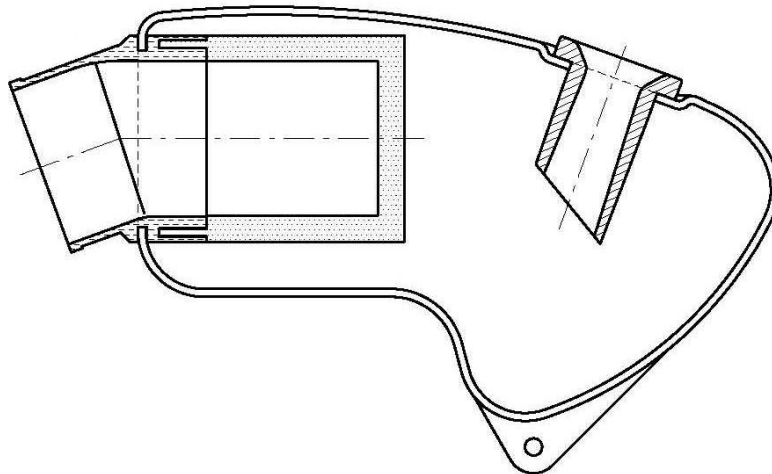

INLET SILENCER - PHOTO
PHOTO - SILENCIEUX D'ASPIRATION



DESCRIPTION OF THE CLUTCH
DESCRIPTION DE L'EMBRAYAGE

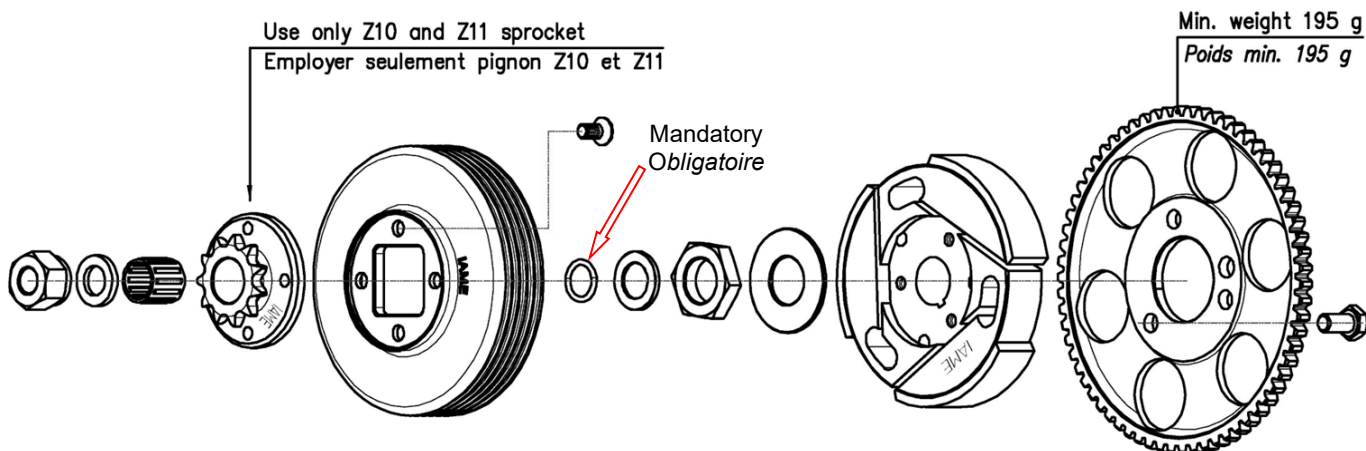

CLUTCH DRUM AND CLUTCH HUB DRAWING
DESSIN DE LA CLOCHE D'EMBRAYAGE ET CORPS D'EMBRAYAGE

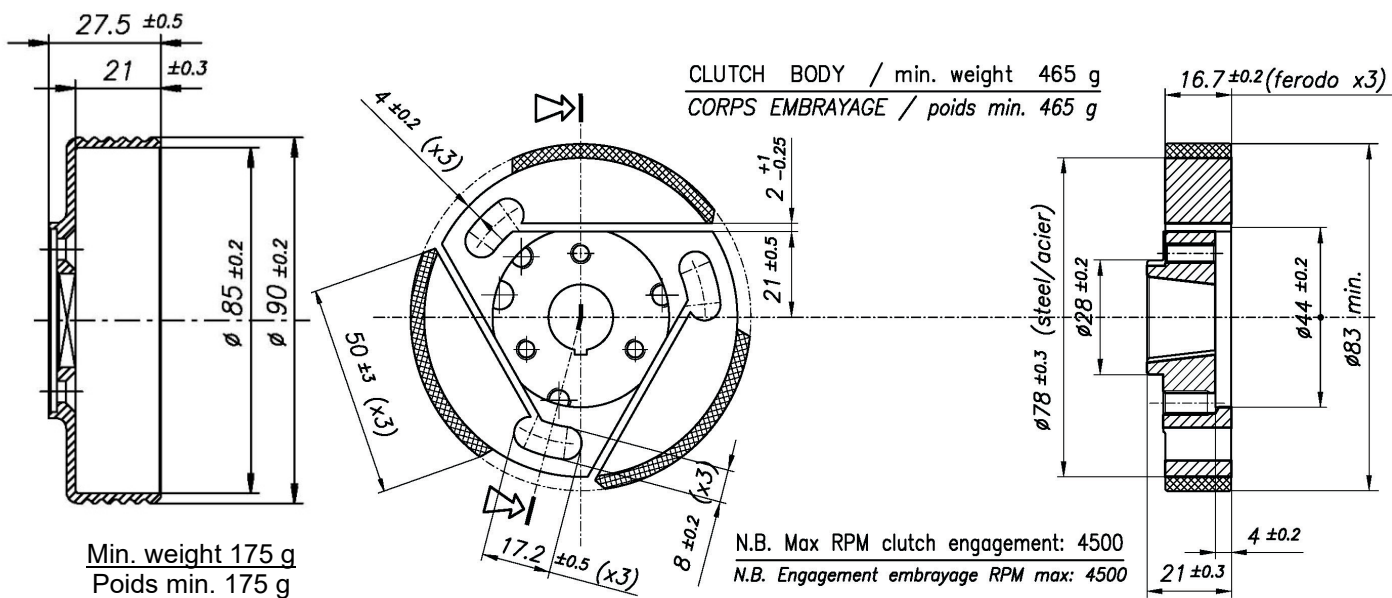

EXHAUST VIEW AND DIMENSIONS (with and without embossed logo)
 VUE ET DIMENSIONS DE L'ÉCHAPPEMENT (avec et sans logo en relief)

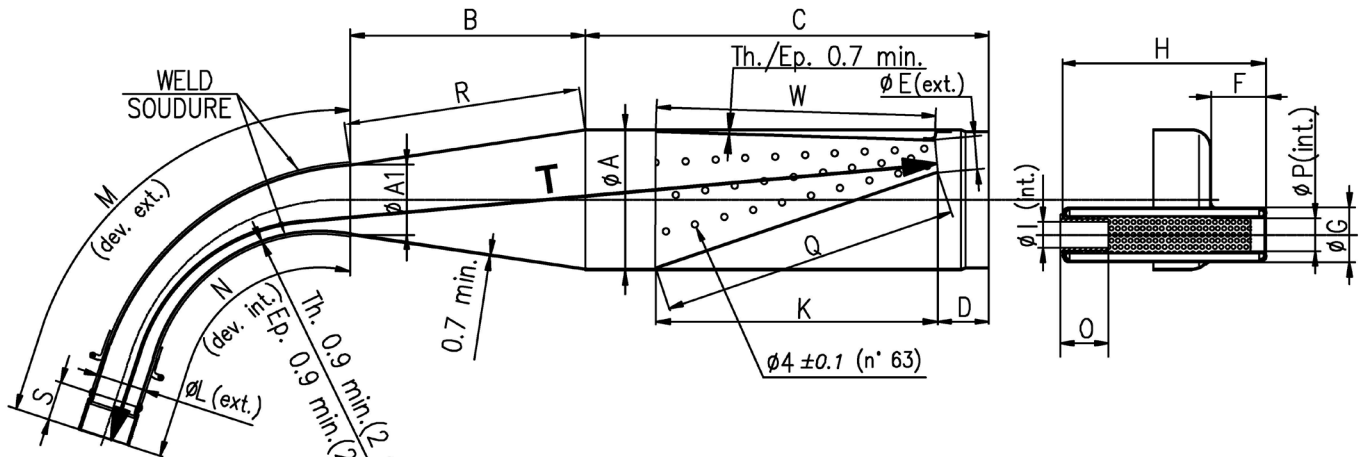

The tape must follow the centerline of the weld at all points
 Le ruban doit suivre l'axe de la soudure en tous points

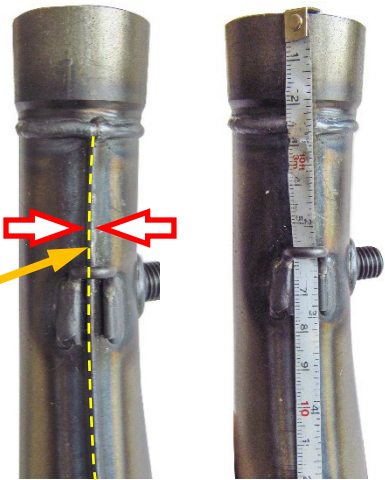

Min. weight 1.250 g
 Poids min.

ØA: 90 ±1.5 Øext.	D: 30 ±2	H: 132 ±2	M: 265 ±3	R: 152 ±3	T: 601 ±3
ØA1: 45 ±1 Øext.	ØE: 20 ±1 Øext.	ØI: 17 max Øint.	N: 215 ±3	S: 25 ±1	
B: 150 ±3	F: 35 ±2	K: 181 ±3	O: 30 min.	Q: 192 ±3	
C: 260 ±3	ØG: 35 ±1 Øext.	ØL: 31 ±1.5 Øext.	ØP: 21 ±1 Øint.	W: 181 ±3	

ATTENTION:

The dimensions "M", "N" and "T" must be taken by steel tape measure 6mm wide.
 Les dimensions « M », « N » et « T » doivent être à l'aide d'un ruban à mesurer en acier 6 mm de large.

The dimensions "M" and "N" must be taken on the weld centerline.
 Les dimensions « M », « N » doivent être prises sur l'axe de la soudure.

The dimensions "Q" and "W" must be taken by steel tape measure 12mm wide.
 Les dimensions « Q » et « W » doivent être prises à l'aide d'un ruban à mesurer en acier 12 mm de large.

ALTERNATIVE EXHAUST with embossed logo
ECHAPPEMENT ALTERNATIVE avec logo en relief



MARKING / MARQUAGE

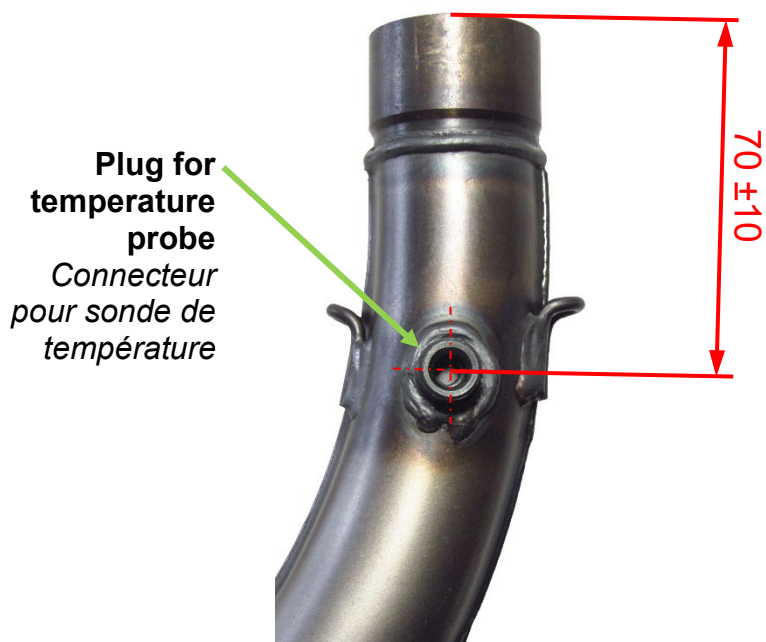

EXHAUST EXIT VIEW AND DIMENSION
VEU ET DIMENSIONS DU SORTIE D'ÉCHAPPEMENT

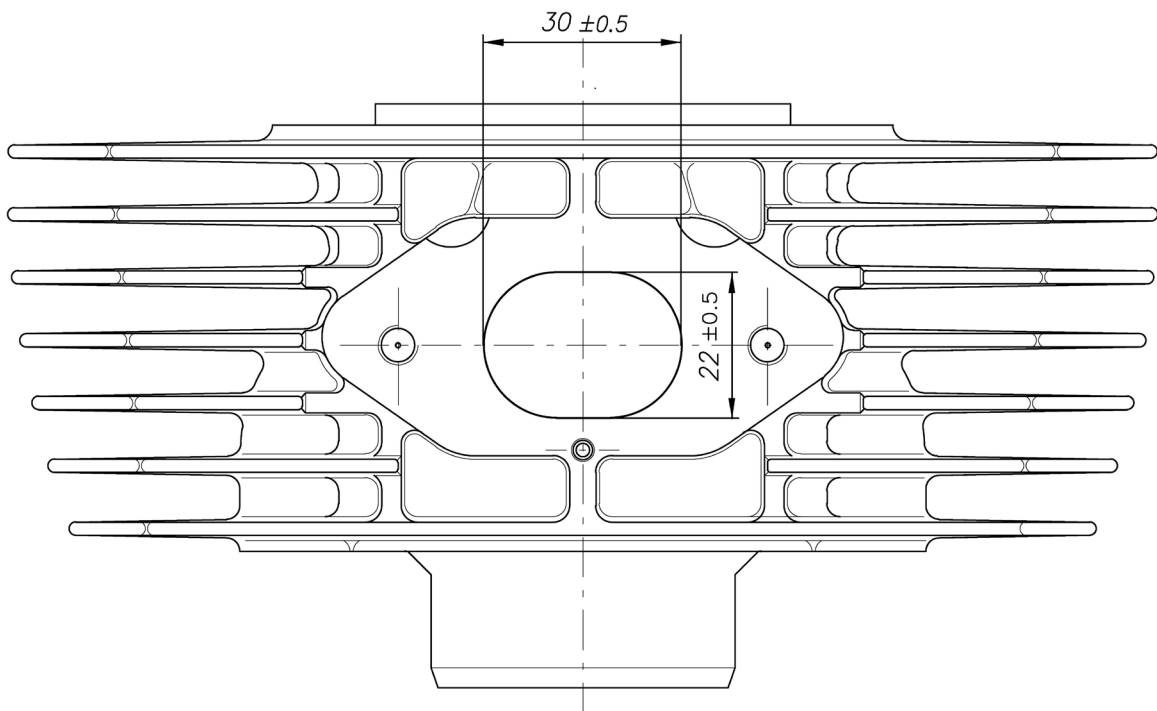

EXHAUST FITTING
RACCORD D'ÉCHAPPEMENT

Restricted Ø18.3 MAX

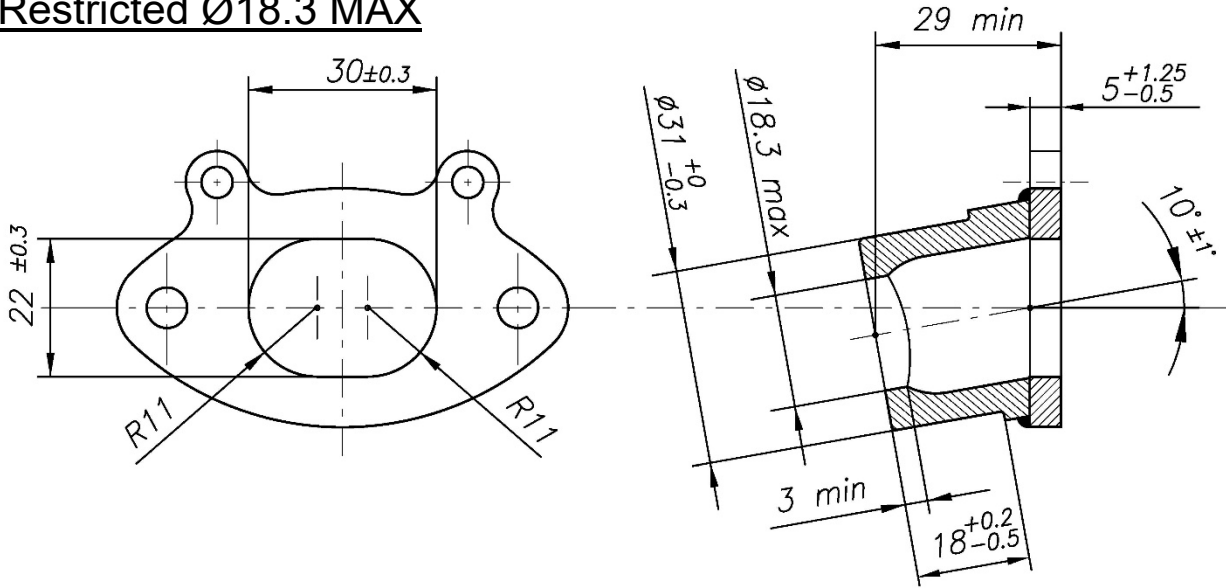

Restricted Ø16 MAX

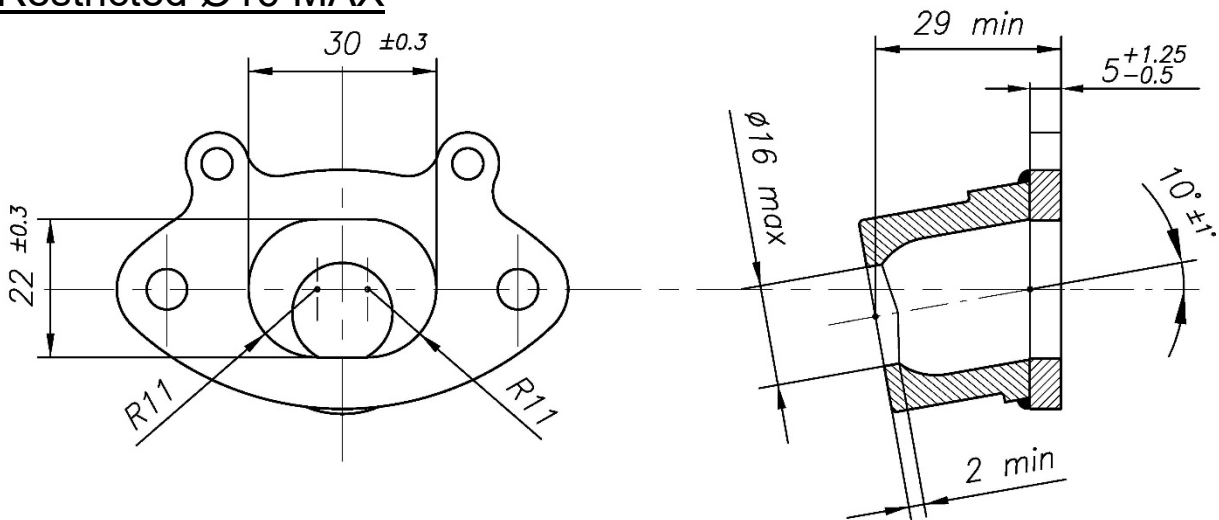

Unrestricted

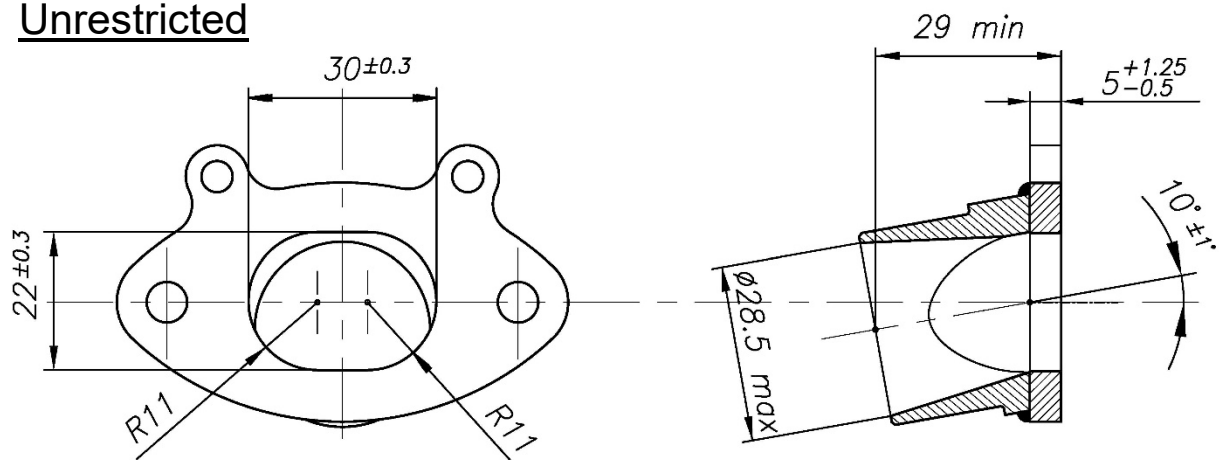

WIRING DIAGRAM
SCHEMA CIRCUIT ELECTRIQUE

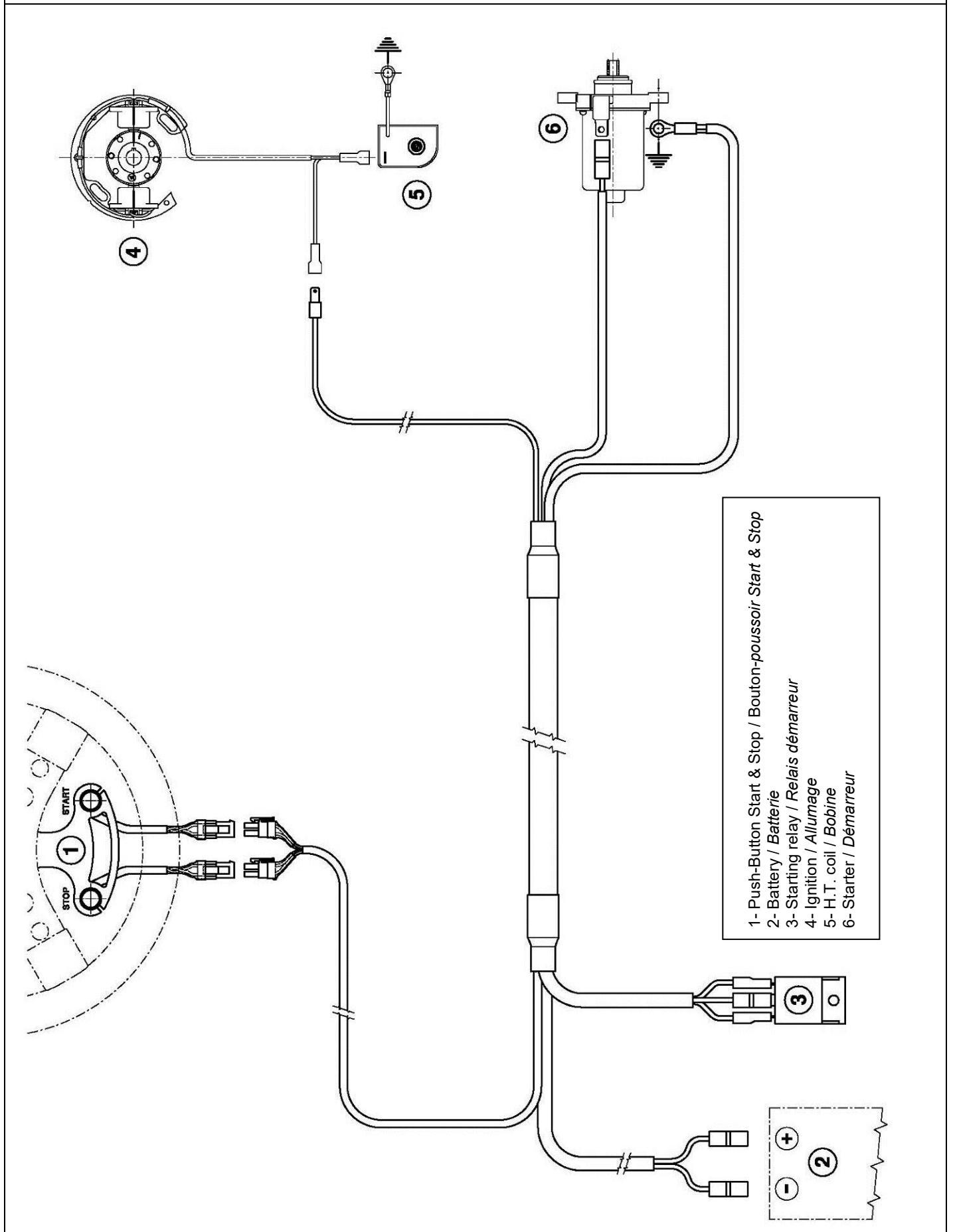

- 1- Push-Button Start & Stop / Bouton-poussoir Start & Stop
- 2- Battery / Batterie
- 3- Starting relay / Relais démarreur
- 4- Ignition / Allumage
- 5- H.T. coil / Bobine
- 6- Starter / Démarreur

PHOTO COMPLETE WIRING
PHOTO DU CÂBLAGE ÉLECTRIQUE COMPLÈTE

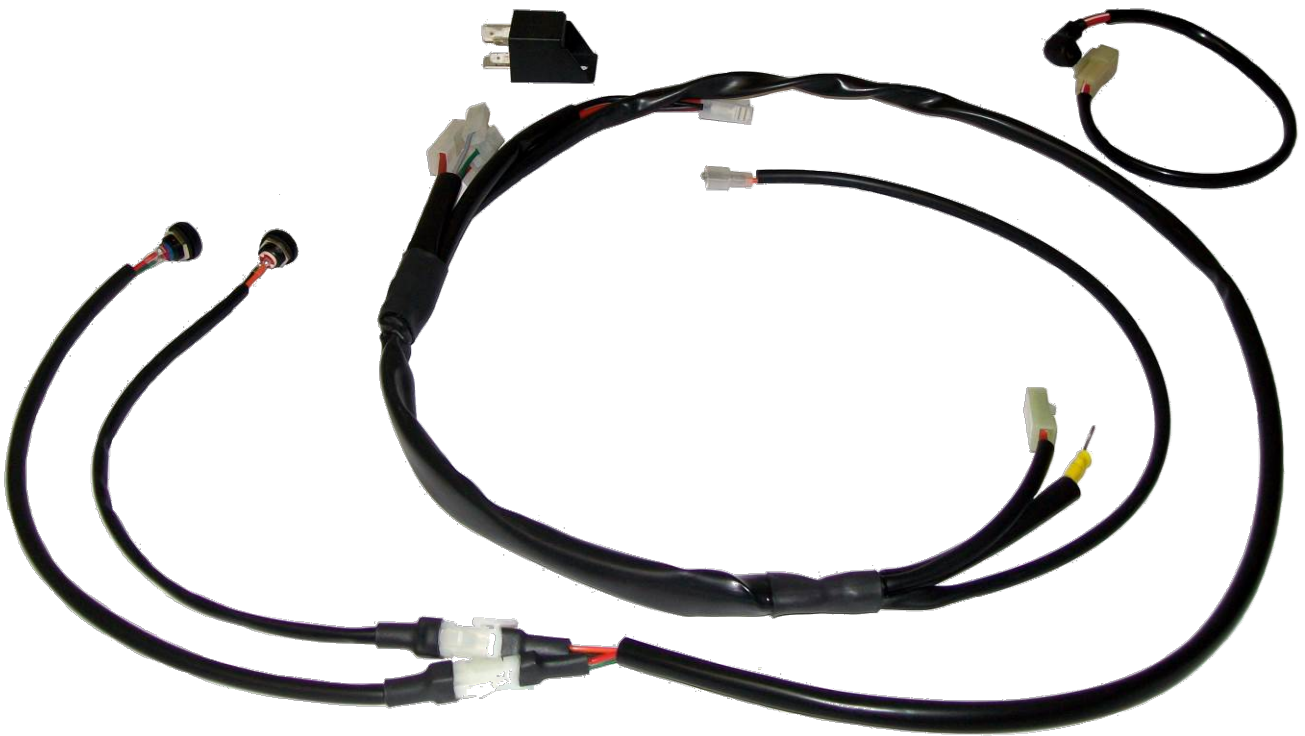
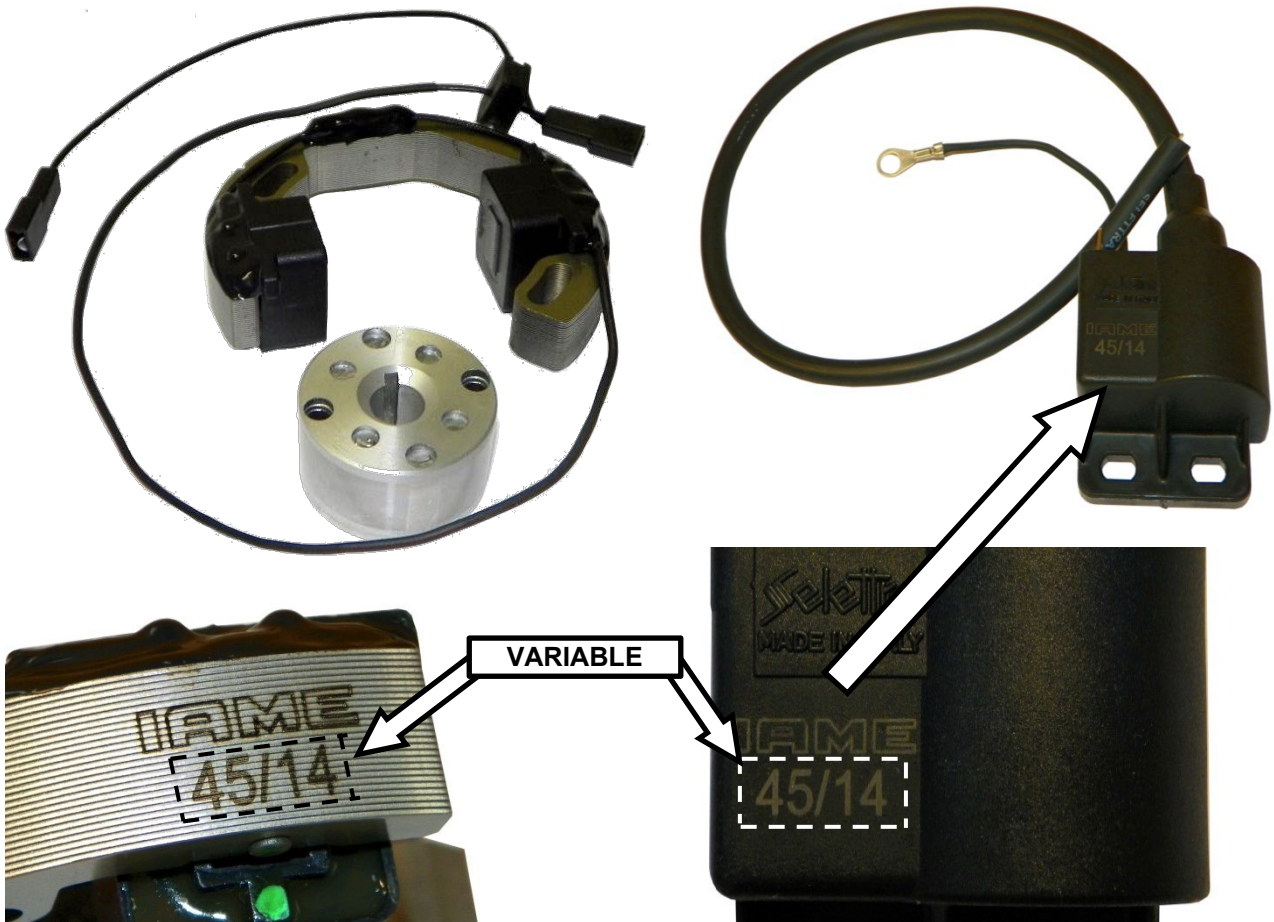
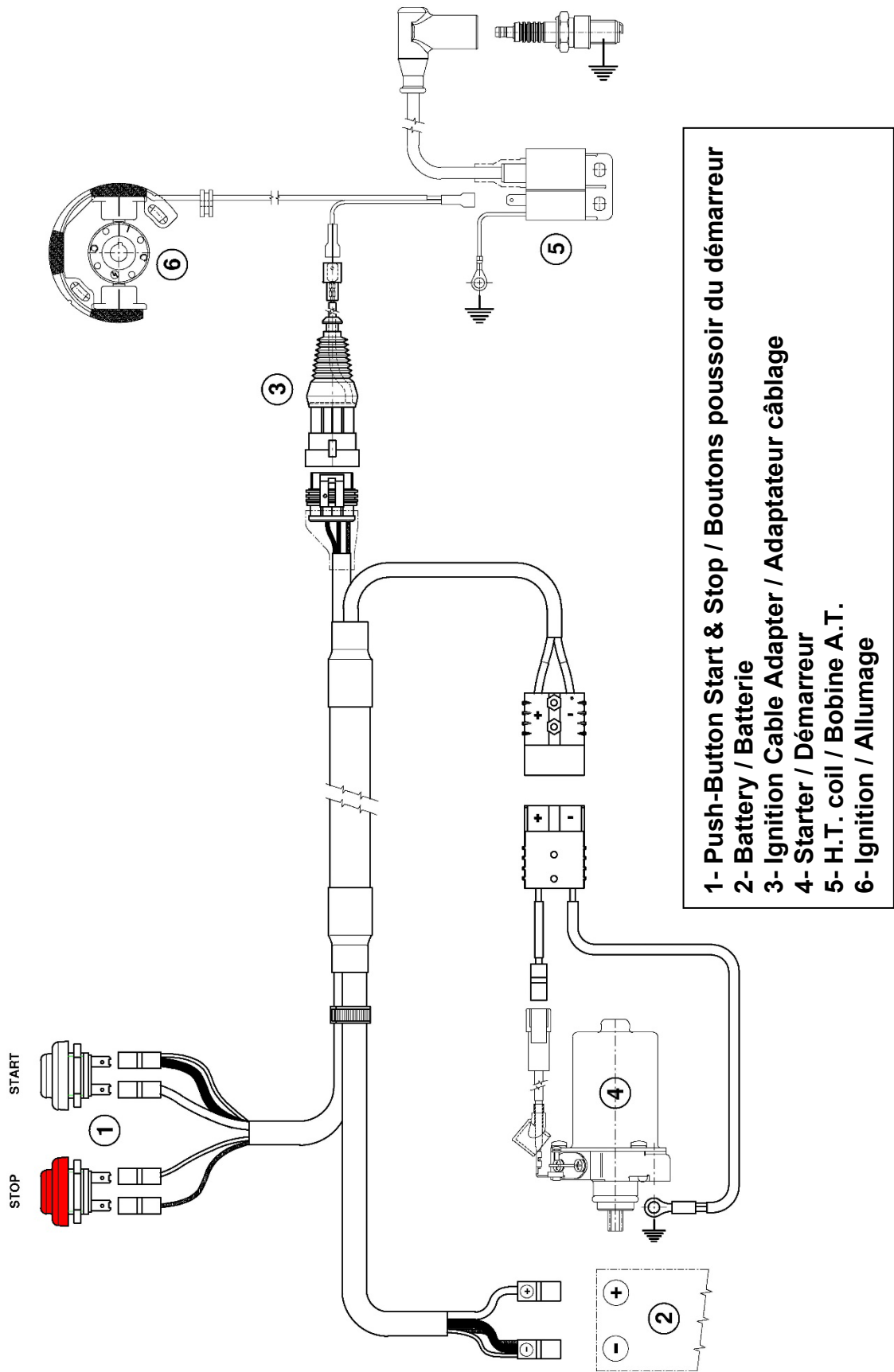

PHOTO OF IGNITION / PHOTO OF H.T. COIL (SELETTA ANALOGUE 2 POLES)
PHOTO DU ALLUMAGE ET BOBINE



ALTERNATIVE WIRING LOOM DIAGRAM
 SCHÉMA CIRCUIT ÉLECTRIQUE ALTERNATIF



- 1- Push-Button Start & Stop / Boutons poussoir du démarreur
- 2- Battery / Batterie
- 3- Ignition Cable Adapter / Adaptateur câblage
- 4- Starter / Démarreur
- 5- H.T. coil / Bobine A.T.
- 6- Ignition / Allumage

PHOTO OF ALTERNATIVE COMPLETE WIRING LOOM
PHOTO DU CÂBLAGE ÉLECTRIQUE COMPLÈTE ALTERNATIF



CYLINDER IDENTIFICATION MARKING
MARQUAGE D'IDENTIFICATION DU CYLINDRE

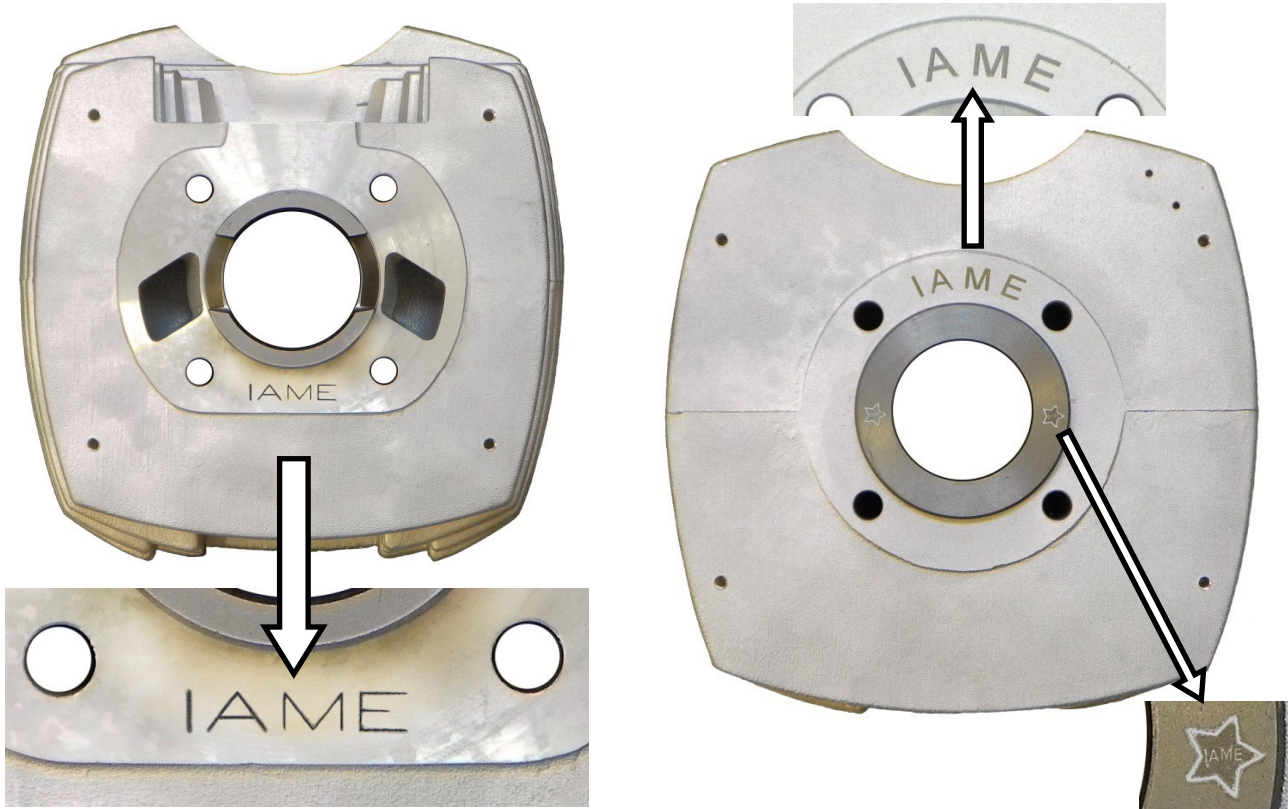

HEAD IDENTIFICATION MARKING
MARQUAGE D'IDENTIFICATION DE LA CULASSE

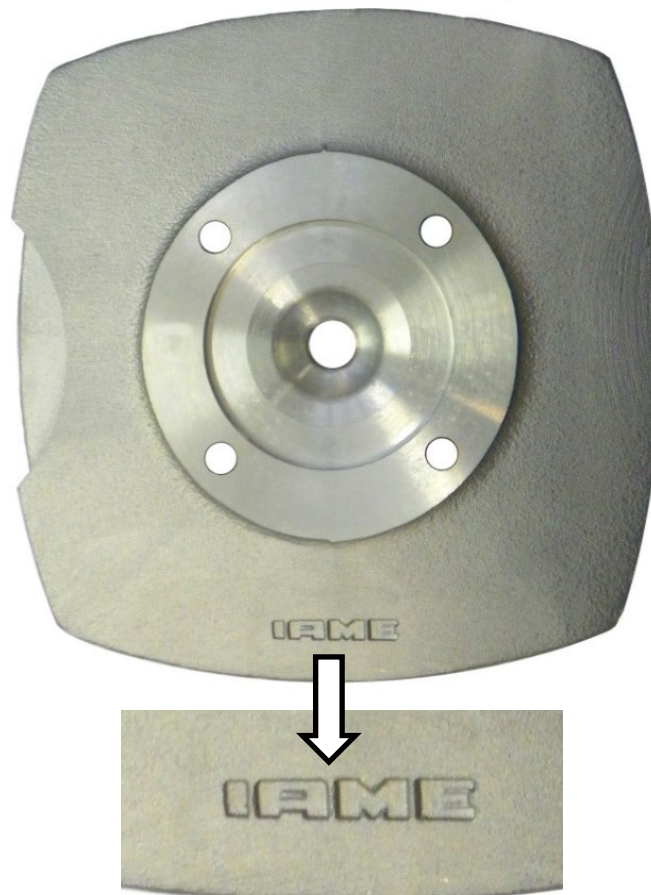

SEMICARTER IGNITION SIDE AND TRANSMISSION SIDE IDENTIFICATION MARKING
MARQUAGE D'IDENTIFICATION DU SEMICARTER CÔTÉ ALLUMAGE ET PIGNON

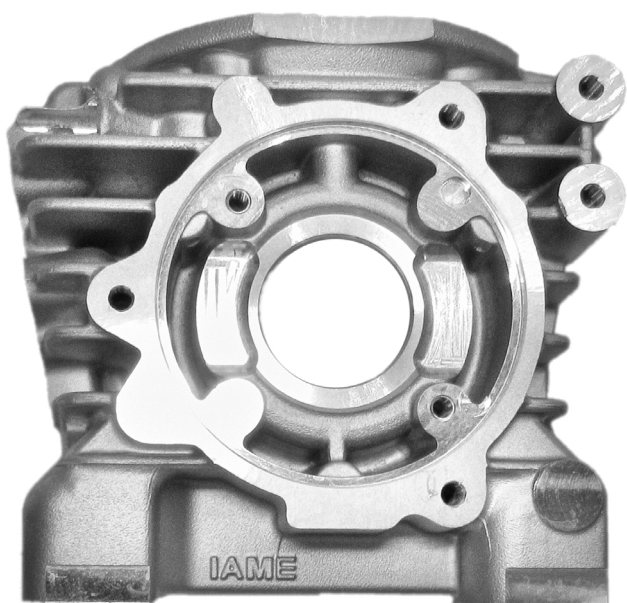

STARTER RING IDENTIFICATION MARKING
MARQUAGE D'IDENTIFICATION DE LA COURONNE DE DEMARRAGE

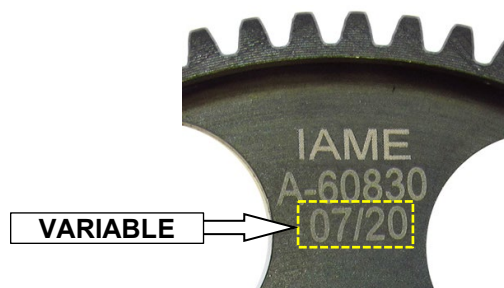

CRANKSHAFT PHOTOS
 PHOTO D'IDENTIFICATION DU VILEBREQUIN

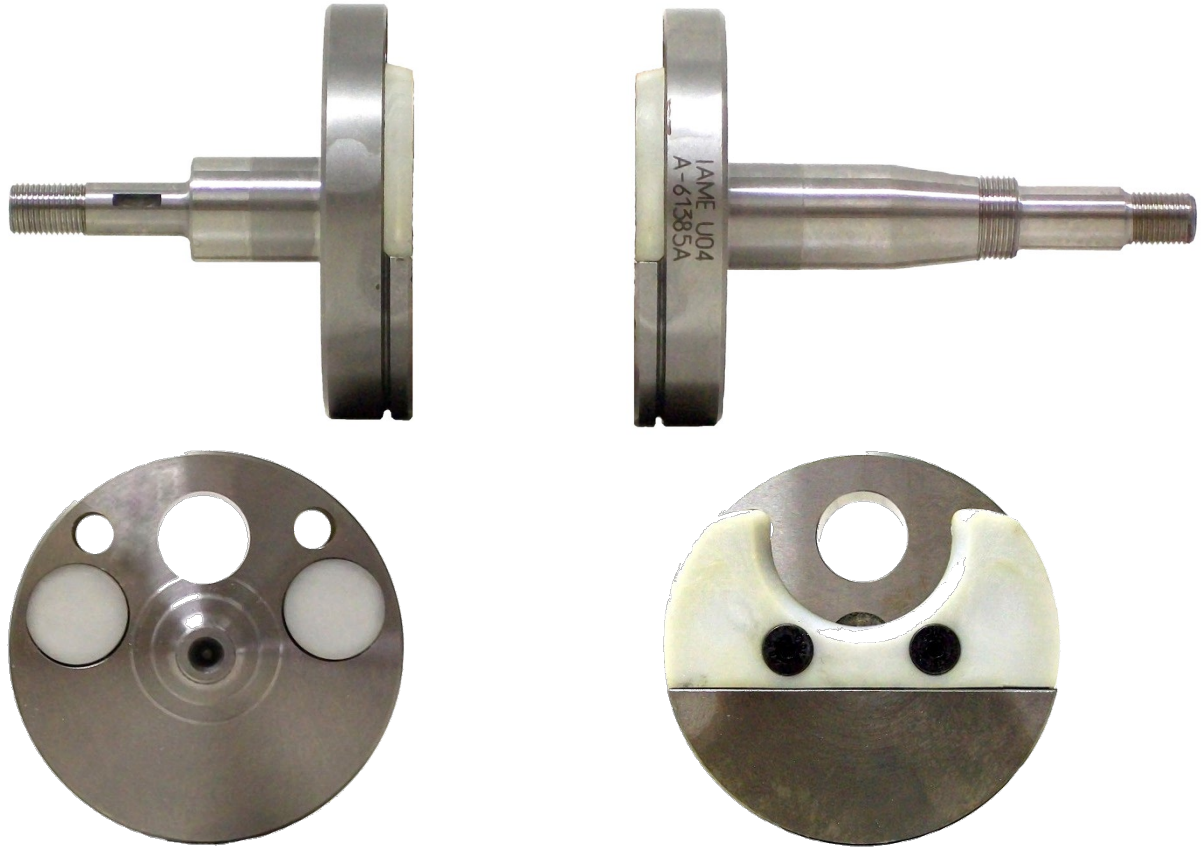
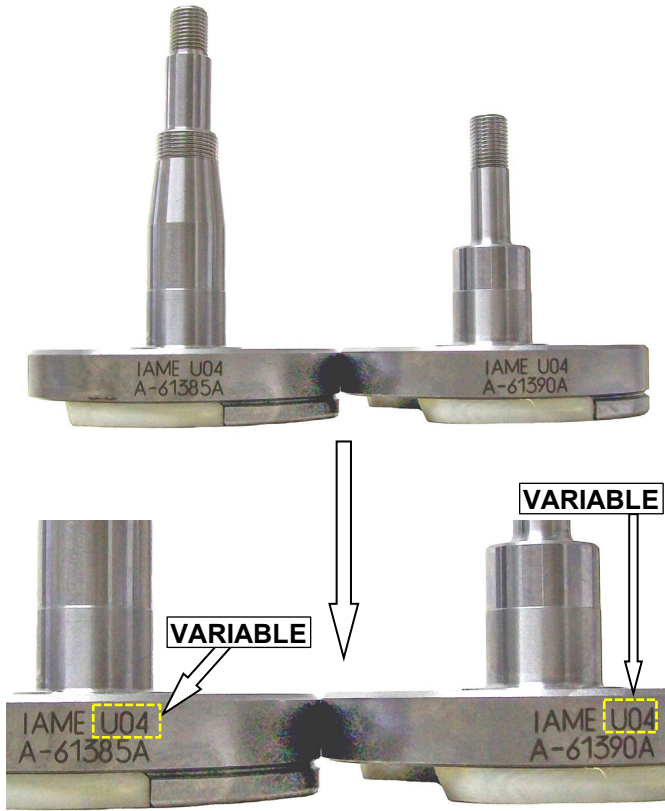

PHOTO OF COMPLETE CRANKSHAFT
 PHOTO DU VILEBREQUIN COMPLETE

EXHAUST without embossed logo
 ECHAPPEMENT sans logo en relief



CRANKSHAFT IDENTIFICATION MARKINGS
 MARQUAGE D'IDENTIFICATION DU
 VILEBREQUIN



CONROD AND PISTON IDENTIFICATION MARKINGS
 MARQUAGE D'IDENTIFICATION BIELLE
 ET PISTON

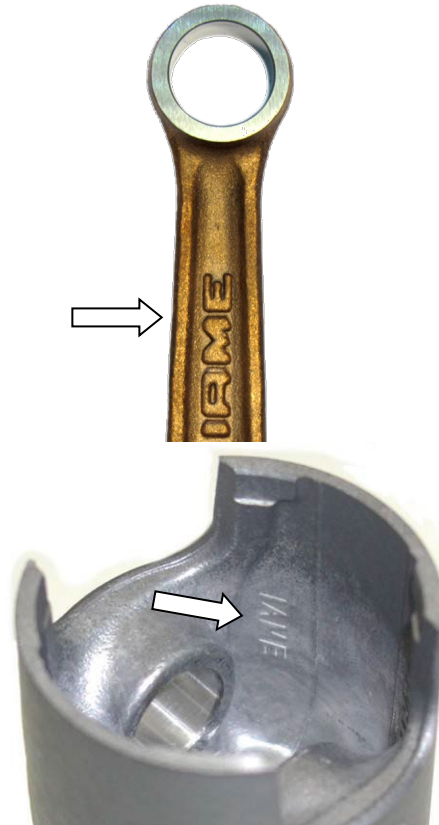

CLUTCH HUB IDENTIFICATION MARKING
 MARQUAGE D'IDENTIFICATION CORPS DE
 EMBRAYAGE



CLUTCH DRUM IDENTIFICATION MARKING
 MARQUAGE D'IDENTIFICATION DE LA
 CALOTTE



IGNITION COVER IDENTIFICATION
MARKING
MARQUAGE D'IDENTIFICATION
COUVERCLE DU ALLUMAGE

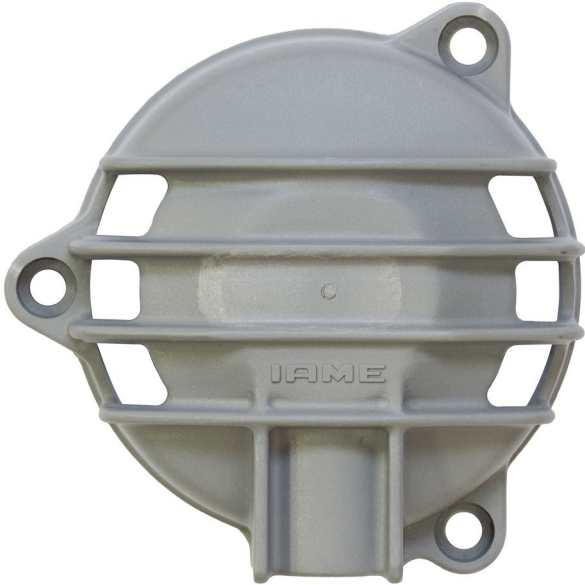

CLUTCH COVER IDENTIFICATION
MARKING
MARQUAGE D'IDENTIFICATION
COUVERCLE D'EMBRAYAGE



INLET FILTER IDENTIFICATION MARKING
MARQUAGE D'IDENTIFICATION SILENCIEUX D'ASPIRATION



PHOTO IDENTIFICATION OF CONROD – ALTERNATIVE TYPES
PHOTO D' IDENTIFICATION DE LA BIELLE – TYPES ALTERNATIFS

TYPE 1



TYPE 2



PARTICULARS WITH ALTERNATIVE NEW LOGO "IAME"
PARTICULARITÉS AVEC UN NOUVEAU LOGO ALTERNATIF «IAME»

CYLINDER
CYLINDRE

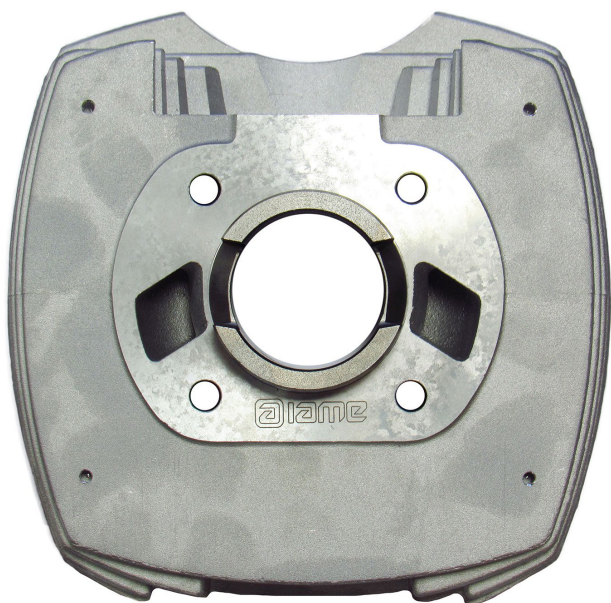

NEW LOGO



NEW LOGO



CYLINDER HEAD
CULASSE



NEW LOGO



PARTICULARS WITH ALTERNATIVE NEW LOGO "IAME"
PARTICULARITÉS AVEC UN NOUVEAU LOGO ALTERNATIF «IAME»

SEMICARTER IGNITION SIDE
SEMICARTER CÔTÉ ALLUMAGE

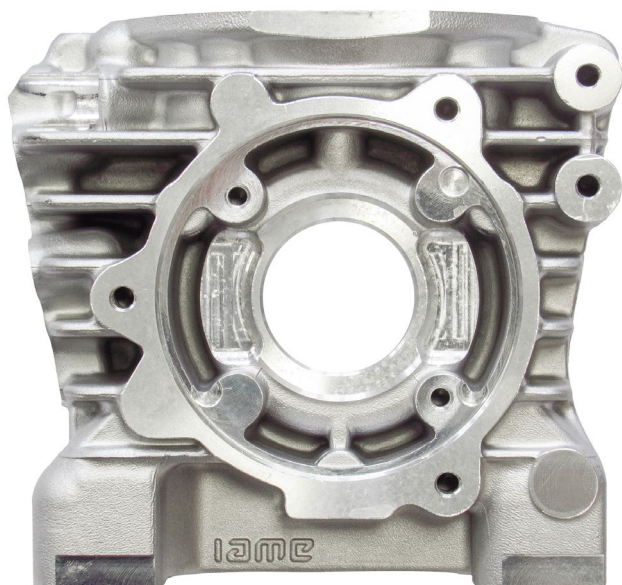

NEW LOGO



SEMICARTER TRANSMISSION SIDE
SEMICARTER CÔTÉ PIGNON

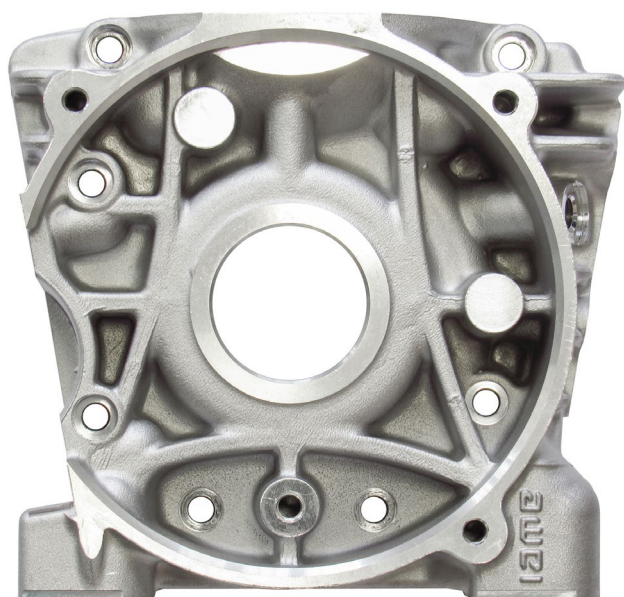

NEW LOGO



PARTICULARS WITH ALTERNATIVE NEW LOGO "IAME"
PARTICULARITÉS AVEC UN NOUVEAU LOGO ALTERNATIF «IAME»

CLUTCH HUB
SEMICARTER CÔTÉ ALLUMAGE



NEW LOGO

VARIABLE

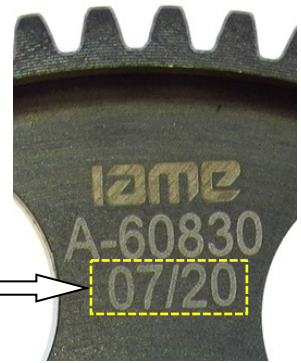

EXHAUST without embossed logo
ECHAPPEMENT sans logo en relief

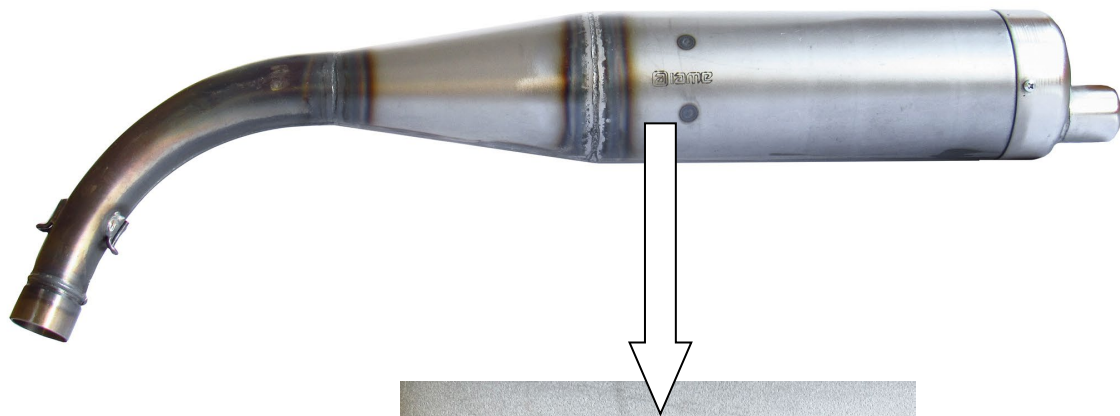

NEW LOGO



PARTICULARS WITH ALTERNATIVE NEW LOGO "IAME"
PARTICULARITÉS AVEC UN NOUVEAU LOGO ALTERNATIF «IAME»

IGNITION COVER
COUVERCLE DU ALLUMAGE

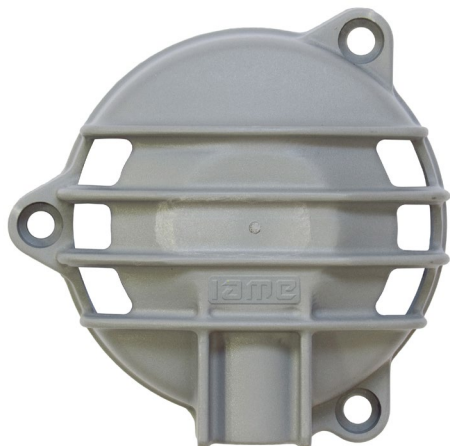

NEW LOGO



CLUTCH COVER
COUVERCLE D'EMBRAYAGE



NEW LOGO



INLET FILTER
SILENCIEUX D'ASPIRATION



NEW LOGO



PARTICULARS WITH ALTERNATIVE NEW LOGO "IAME"
PARTICULARITÉS AVEC UN NOUVEAU LOGO ALTERNATIF «IAME»

THE OTHERS COMPONENTS OF ENGINE THAT ARE MARKED (LASER OR PUNCHING) UNTIL TODAY WITH LOGO OR WRITTEN "IAME"

LES AUTRES COMPOSANTS DU MOTEUR AVEC MARQUAGE (LASER OU POINÇONNEUSE) AUJOURD'HUI AVEC LE LOGO OU ÉCRIT «IAME»

I A M E

or

IAME

NOW COULD BE MARKED WITH NEW LOGO "IAME"
MAINTENANT POURRAIT EST MARQUAGE AVEC UN NOUVEAU LOGO
"IAME"

IAME

or

IAME

or

IAME



CARBURETTOR / CARBURATEUR
Tillotson HW-31A

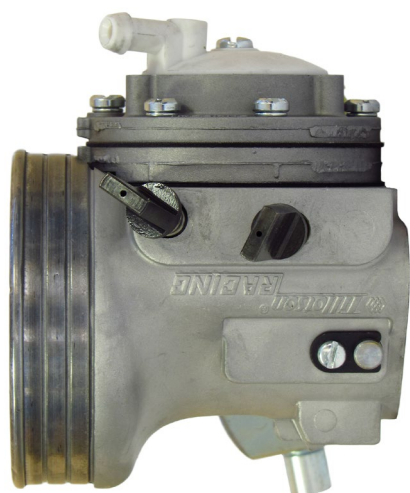

PHOTO OF ADJUSTING SIDE
 PHOTO CÔTÉ RÉGLAGE

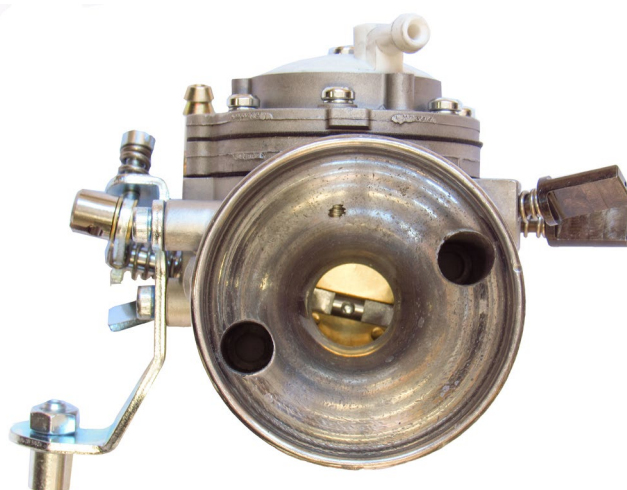
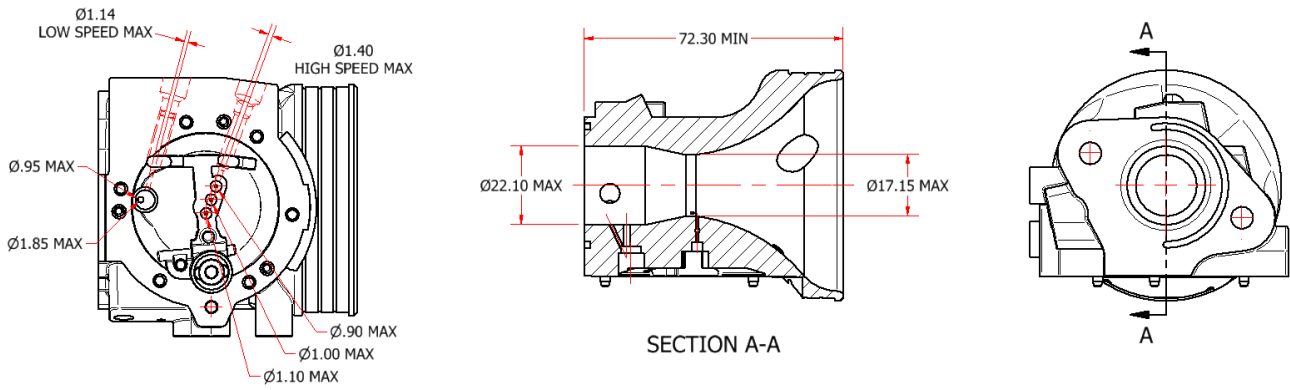

PHOTO OF INLET SIDE
 PHOTO CÔTÉ ASPIRATION

Manufacturer - <i>Manufacteur</i>	TILLOTSON LTD.
Make - <i>Marque</i>	TILLOTSON
Model - <i>Modèle</i>	HW-31A

SECTION VIEW – VUE DE SECTION AVEC DIMENSIONS



“IAME” MARKING – MARQUAGE “IAME”

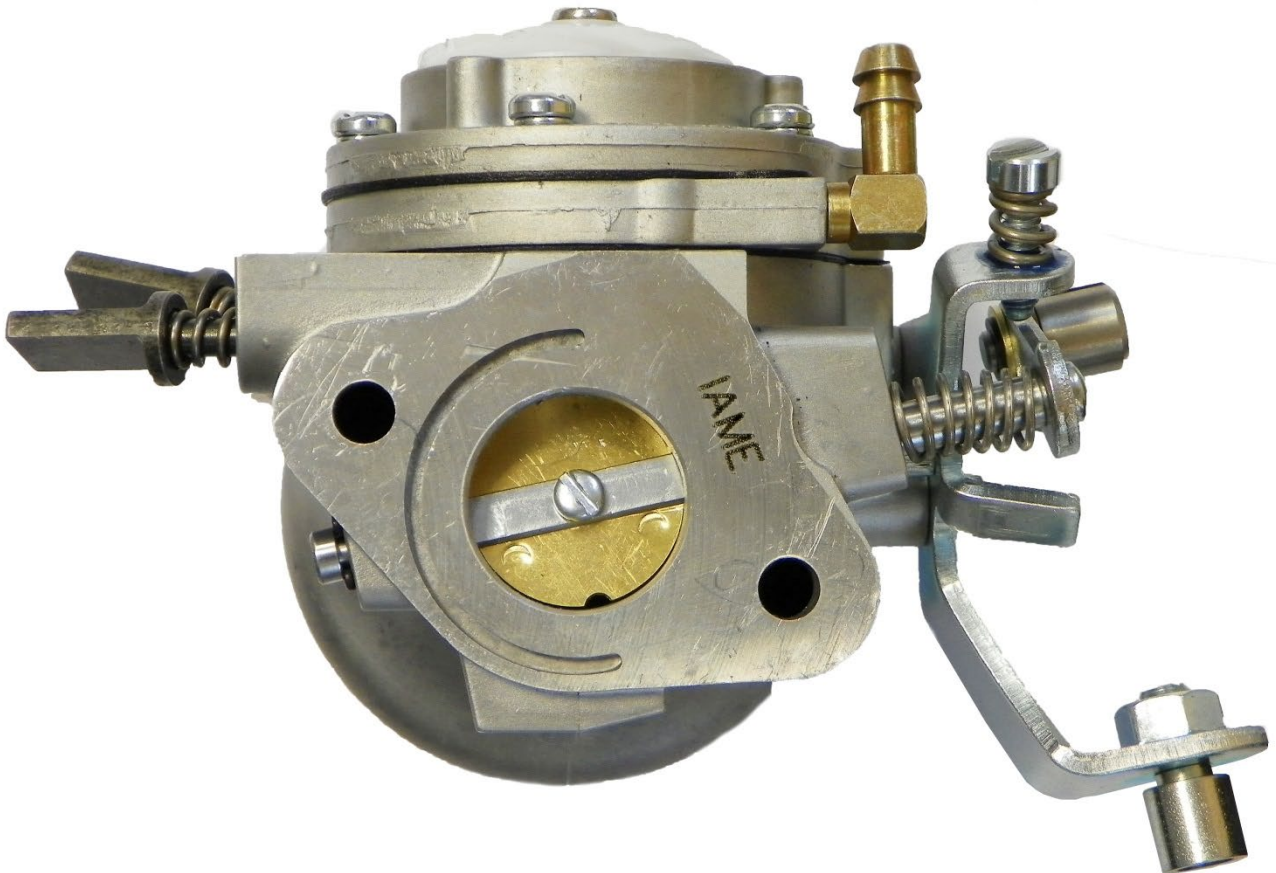

CARBURETTOR - DESCRIPTION AND SKETCH OF PARTS CARBURATEUR - DESCRIPTION ET DESSIN DES PIÈCES

HW-31A

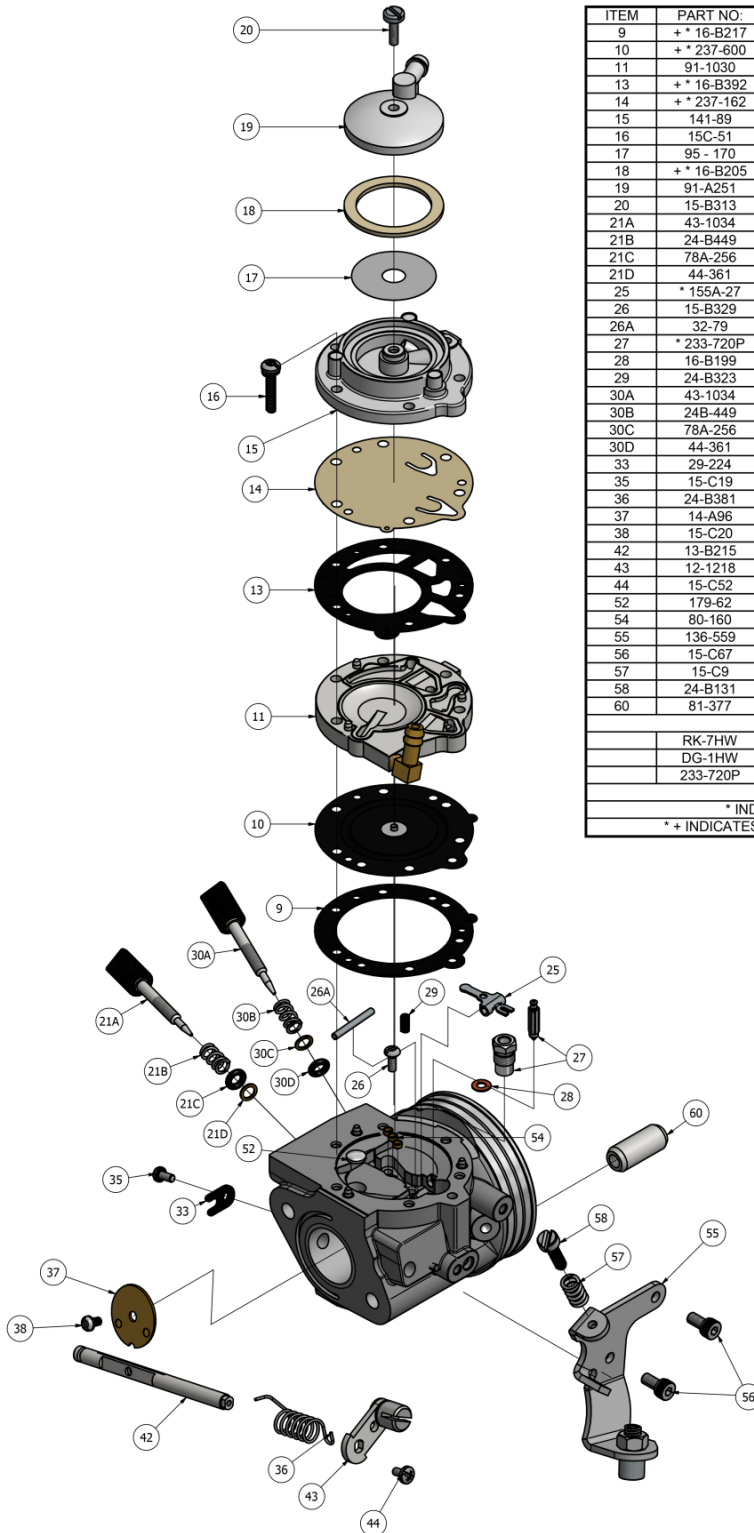

ITEM	PART NO:	DESCRIPTION	QTY
9	+ * 16-B217	DIAPHRAGM GASKET	1
10	+ * 237-600	DIAPHRAGM	1
11	91-1030	DIAPHRAGM COVER	1
13	+ * 16-B392	FUEL PUMP GASKET	1
14	+ * 237-162	FUEL PUMP DIAPHRAGM	1
15	141-89	FUEL PUMP BODY	1
16	15C-51	FUEL PUMP BODY SCREW	6
17	95 - 170	FUEL STRAINER SCREEN	1
18	+ * 16-B205	FUEL STRAINER COVER GASKET	1
19	91-A251	FUEL STRAINER COVER	1
20	15-B313	FUEL STRAINER COVER RETAINING SCREW	1
21A	43-1034	IDLE MIXTURE SCREW	1
21B	24-B449	IDLE MIXTURE SCREW SPRING	1
21C	78A-256	IDLE MIXTURE SCREW WASHER	1
21D	44-361	IDLE MIXTURE SCREW PACKING	1
25	* 155A-27	INLET CONTROL LEVER	1
26	15-B329	FULCRUM LEVER SCREW	1
26A	32-79	FULCRUM LEVER PIN	1
27	* 233-720P	INLET NEEDLE & SEAT SET	1
28	16-B199	INLET SEAT GASKET	1
29	24-B323	INLET TENSION SPRING	1
30A	43-1034	HIGH SPEED MIXTURE SCREW	1
30B	24B-449	HIGH SPEED MIXTURE SCREW SPRING	1
30C	78A-256	HIGH SPEED MIXTURE SCREW WASHER	1
30D	44-361	HIGH SPEED MIXTURE SCREW PACKING	1
33	29-224	THROTTLE SHAFT CLIP	1
35	15-C19	THROTTLE SHAFT CLIP RETAINING SCREW	1
36	24-B381	THROTTLE RETURN SPRING	1
37	14-A96	THROTTLE SHUTTER	1
38	15-C20	THROTTLE SHUTTER SCREW	1
42	13-B215	THROTTLE SHAFT	1
43	12-1218	THROTTLE LEVER ASSEMBLY	1
44	15-C52	THROTTLE LEVER RETAINING SCREW	1
52	179-62	WELCH PLUG	1
54	80-160	MAIN PLUG	3
55	136-559	CABLE BRACKET	1
56	15-C67	CABLE BRACKET RETAINING SCREW	2
57	15-C9	LIMITER SCREW	2
58	24-B131	LIMITER SPRING	2
60	81-377	CARBURETTOR MOUNTING NUT	2
	RK-7HW	REPAIR KIT	
	DG-1HW	DIAPHRAGM & GASKET (STANDARD)	
	233-720P	INLET NEEDLE & SEAT SET	
* INDICATES CONTENTS OF REPAIR KIT			
* + INDICATES CONTENTS OF DIAPHRAGM & GASKET SET			



Clash Industrial Estate - Tralee - Ireland
www.tillotson-racing.com



PARTS OF CARBURETTOR – PIÈCES DU CARBURATEUR

REF.9 - P. N°16-B217
DIAPHRAGM GASKET
JOINT DE DIAPHRAGME



Thickness / *Epaisseur* = 0.5 ±0.1 mm

REF.13 - P. N° 16-B392
PUMP DIAPHRAGM GASKET
JOINT DE POMPE A ESSENCE

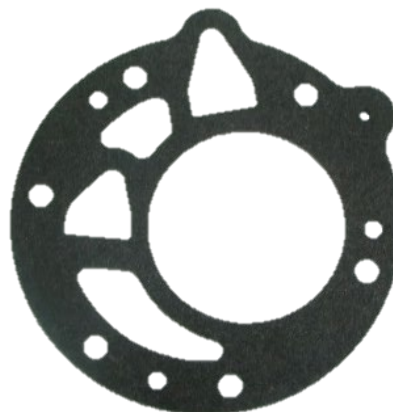

Thickness / *Epaisseur* = 0.8 ±0.1 mm

REF.10 - P. N°237-600
DIAPHRAGM
DIAPHRAGME ASSEMBLE



Thickness / *Epaisseur* = 0.13 ±0.07 mm

REF.14 - P. N°237-162
PUMP DIAPHRAGM
MEMBRANE DE POMPE A ESSENCE



Thickness / *Epaisseur* = 0.10 ±0.063 mm

REF.11 - P. N° 91-1031
DIAPHRAGM COVER
COUVERCLE DE DIAPHRAGME



Thickness / *Epaisseur* = 6.75 ±0.15 mm

REF.15 - P. N° 141-89
PUMP COVER
CORPS DE POMPE A ESSENCE



Thickness / *Epaisseur* = 12.5 ±0.15 mm

REF.37 - P. N° 14-A96
 THROTTLE SHUTTER
 PAPILLON

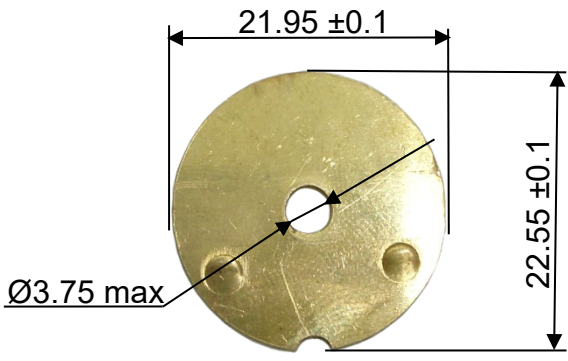

Thickness / Epaisseur = 0.81 ±0.1 mm

REF.27 - P. N° 233-720P
 SEAT + NEEDLE
 SIEGE + POINTEAU

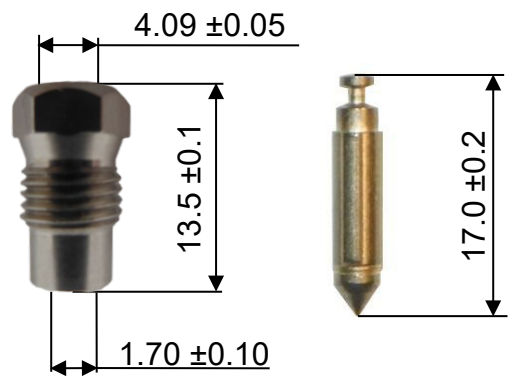

REF.21A - P. N° 43-1034
 NEEDLE LOW SPEED
 VIS DE RAGLAGE BAS-REGIME

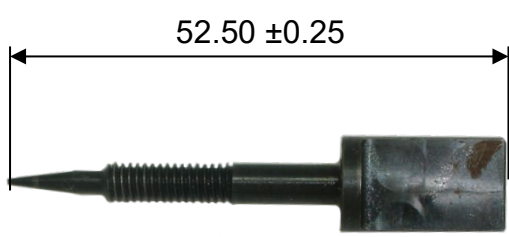

REF.30A - P. N° 43-1034
 NEEDLE HIGH SPEED
 VIS DE RAGLAGE HAUT-REGIME

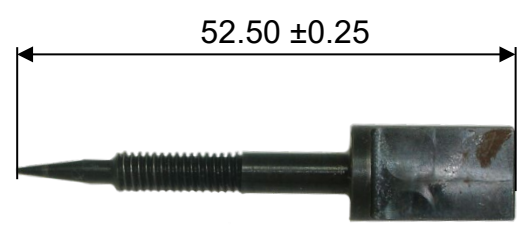

NEEDLE FUEL ALTERNATIVE
 POINTEAU ALTERNATIVE

REF.27 - P. N° 233-720P

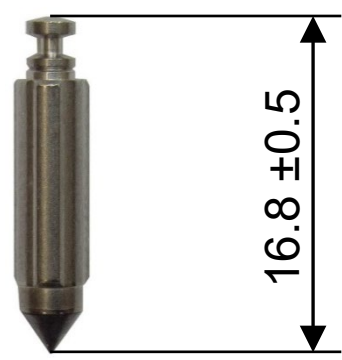

HOLE FOR CARBURETTOR SEALING
 TROU POUR LE PLOMBAGE

The carburettor can have this hole for sealing.
 Le carburateur peut avoir ce trou pour le plombage

